

## TANDÉR

### IR91SN IR Night Vision Camera

#### Main Features:

- 1/3" Sony SuperHAD 8mm 420TVL
- Night Vision 91 Infra Red LED / 60M
- Weather Proof Housing: IP68
- Patented Heat Dissipation Housing

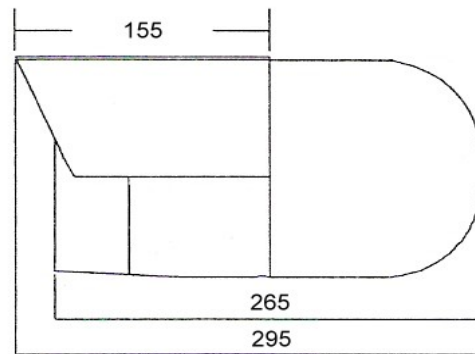
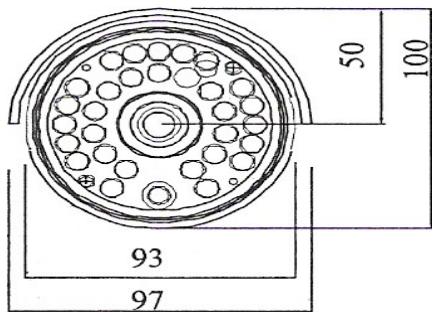

#### SPECIFICATION

Image Chip	1/3" Sony SuperHAD CCD
Infra Red LED	91 pcs
Infra Red Distant	60 Meter
Min. Illumination	0.1 Lux (0 Lux LED on)
Lens	8 mm
Horizontal Resolution	420 TV Line
Effective Pixels (PAL)	500*582
H Scanning Frequency (PAL)	15,625 KHz
V Scanning Frequency (PAL)	50 Hz
Synchronization	Internal
White Balance	Auto
Gain Control	Auto
Gamma	0.45
S/N Ratio	> 48 dB
Video Output	1 Vp-p, 75Ω
Electronic Shutter	Auto, 1/50 - 1/100,000 sec.
Power Supply (± 10%)	DC 12V
Power Consumption (± 10%)	IR on:960mA, IR off:110mA
Operating Temperature	-10°C ~ +60°C
Storage Temperature	-20°C ~ +70°C
Dimension (excluding sun visor)	93mm(D) x 265mm(L)
Weight	Camera: 1600g, Bracket: 500g

Country of Origin : Taiwan

Stock Code: 1.2.01.91.08

Specification may change without prior notification

© TANDÉR All Rights Reserved